

FLOOREQUIPMENTPARTS.COM

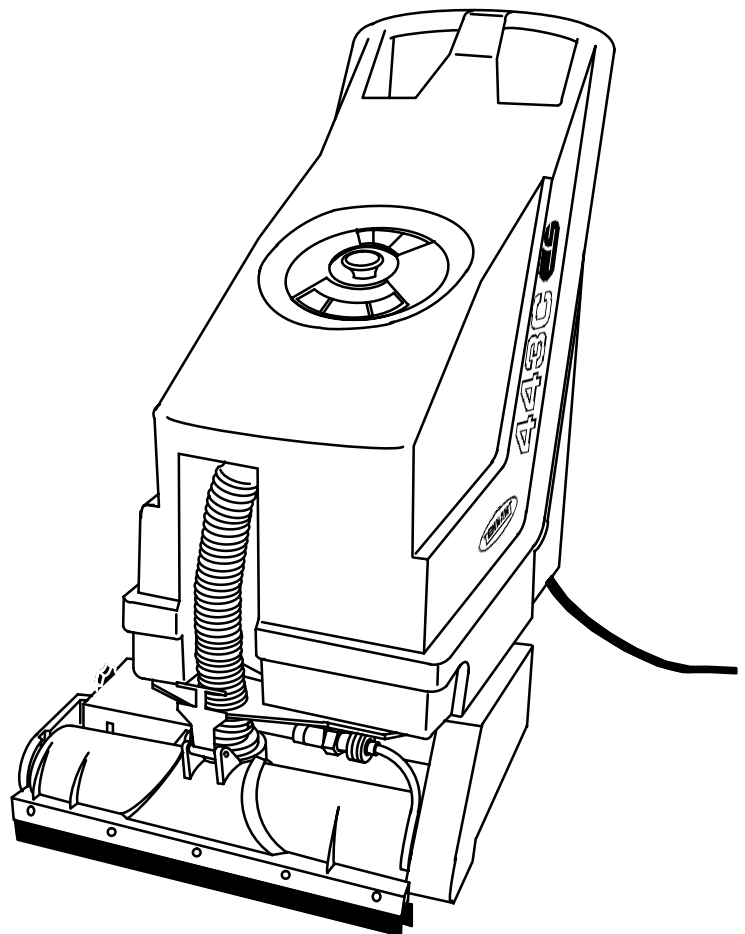

443C

Operator Manual



MM294
578-748
Rev. 05 (06-93)



This manual is furnished with each new TENNANT Model 443C. It provides necessary operating and preventive maintenance instructions. Read this manual completely and understand the machine before operating or servicing it.

This machine will provide excellent service. However, the best results will be obtained at minimum costs if:

- The machine is operated with reasonable care.
- The machine is maintained regularly – per the maintenance instructions provided.
- The machine is maintained with TENNANT supplied or equivalent parts.

Parts and supplies may be ordered by phone or mail from any TENNANT parts and service center, distributor, or from any of the TENNANT subsidiaries. Before ordering parts or supplies, be sure to have your machine model number and serial number handy. Fill out the data block below for future reference.

| |
|---|
| <p style="text-align: center;">MACHINE DATA</p> <p style="text-align: center;"><i>Please fill out at time of installation.</i></p> <p>Machine Serial Number – _____</p> <p>Sales Representative – _____</p> <p>Customer Number – _____</p> <p>Date of Installation – _____</p> <p>Manual Number – MM294</p> <p>Revision: 05</p> <p>Published: 6-93</p> |
|---|

CONTENTS

| | Page | | Page |
|------------------------------------|------|--------------------------------|------|
| SAFETY PRECAUTIONS | 3 | MAINTENANCE | 15 |
| SPECIFICATIONS | 5 | MAINTENANCE REQUIREMENTS | 15 |
| POWER TYPE | 5 | DAILY | 15 |
| POWER TRAIN | 5 | WEEKLY | 15 |
| PROPELLING SYSTEM | 5 | MONTHLY | 15 |
| SUSPENSION SYSTEM | 5 | EVERY THREE MONTHS | 15 |
| SYSTEM REFILL FLUID CAPACITIES ... | 5 | EVERY SIX MONTHS | 15 |
| GENERAL MACHINE DIMENSIONS | 5 | SCRUB HEAD | 15 |
| MACHINE WEIGHT | 5 | DAILY FLUSHING OF SCRUB HEAD . | 15 |
| DIMENSIONS | 5 | MONTHLY CLEANING OF SCRUB | |
| OPERATION | 6 | HEAD | 16 |
| MACHINE COMPONENTS | 6 | SCRUB BRUSH | 17 |
| MODE SWITCH | 7 | REPLACING OR ROTATING | |
| VACUUM FAN SWITCH | 7 | SCRUB BRUSH | 17 |
| BRUSH/SOLUTION LEVER(S) | 7 | SOLUTION DISPENSING TUBE | 18 |
| BRUSH PRESSURE GAUGE | 7 | CLEANING THE DISPENSING TUBE . | 18 |
| BRUSH CIRCUIT BREAKER | 7 | SOLUTION SCREEN FILTER | 19 |
| SCRUB HEAD LIFT LEVER | 7 | REMOVING THE SCRUB HEAD | |
| BRUSH DOWN PRESSURE KNOB ... | 7 | ASSEMBLY | 19 |
| SQUEEGEE HEIGHT ADJUSTMENT | | SQUEEGEE BLADES | 20 |
| RING | 7 | REPLACING SQUEEGEE BLADES ... | 20 |
| PRE-OPERATION CHECKLIST | 8 | STORAGE INFORMATION | 21 |
| TRANSPORTING MACHINE | 8 | FREEZE PROTECTION | 21 |
| FILLING THE SOLUTION TANK | 8 | TROUBLESHOOTING | 22 |
| PREPARING FLOOR FOR SCRUBBING . | 9 | | |
| NORMAL SCRUBBING OPERATION | 9 | | |
| DOUBLE SCRUBBING | 11 | | |
| DRAINING AND CLEANING THE | | | |
| SOLUTION TANK | 11 | | |
| POST-OPERATION CHECKLIST | 12 | | |
| OPTIONS | 13 | | |
| POWER WAND | 13 | | |

SAFETY PRECAUTIONS

The following symbols are used throughout this manual as indicated in their description:

 **CAUTION:** To warn of hazards or unsafe practices which could result in minor personal injury.

 **WARNING:** To warn of hazards or unsafe practices which could result in severe personal injury or death.

FOR SAFETY: To identify actions which must be followed for safe operation of equipment.

The following information signals potentially dangerous conditions to the operator or equipment. Read this manual carefully. Know when these conditions can exist. Locate all safety devices on the machine. Then, take necessary steps to train machine operating personnel. Report machine damage or faulty operation immediately. Do not use the machine if it is not in proper operating condition.

FOR SAFETY:

1. **Do Not Operate, Maintain, or Service Machine:**
 - Unless Trained And Authorized.
 - Unless Operation Manual Is Read And Understood.
 - With Damaged Cord Or Plug.
 - In Outdoor Areas.
 - In Flammable Or Explosive Areas.
2. **Before Operating Machine:**
 - Make Sure All Safety Devices Are In Place And Operate Properly.
3. **When Using Machine:**
 - Use Only TENNANT Attachments.
 - Do Not Pull Machine By Plug Or Cord.
 - Keep Cord Away From Heated Surfaces.
 - Do Not Unplug By Pulling On Cord.
 - Connect To Properly Grounded Outlet Only. See **GROUNDING INSTRUCTIONS**.
 - Do Not Close Door On Plug Or Pull Cord Around Sharp Corners.
4. **Before Leaving Or Servicing Machine:**
 - Turn Off Machine And Unplug Power Cord From Outlet.

5. **When Maintaining or Servicing Machine:**
 - Avoid Moving Parts. Do Not Wear Loose Jackets, Shirts, Ties, Or Sleeves When Working On Machine.
 - Use TENNANT Supplied Or Equivalent Replacement Parts.

 **WARNING:** Hazardous Voltage. Shock Or Electrocution Can Result. Unplug Power Cord Before Working On Machine.

 **WARNING:** Flammable Materials Can Cause An Explosion Or Fire. Do Not Use Flammable Materials In Solution Tank.

 **WARNING:** Flammable Materials Or Reactive Metals Can Cause An Explosion Or Fire. Do Not Pick Up Flammable Materials Or Reactive Metals.

 **CAUTION:** Moving parts. Unplug Power Cord Before Working On Machine.

GROUNDING INSTRUCTIONS

This machine must be grounded. If it should malfunction or breakdown, grounding provides a path of least resistance for electrical current to reduce the risk of electric shock. This machine is equipped with a cord having an equipment-grounding conductor and grounding plug. The plug must be plugged into an appropriate outlet that is properly installed in accordance with all local codes and ordinances.

FOR SAFETY: Connect To Properly Grounded Outlet Only.

This machine is designed for use on a nominal 120 volt circuit and has a grounding plug that resembles the plug illustrated below. Make sure the machine is connected to an outlet having the same configuration as the plug. No adaptor should be used with this machine.

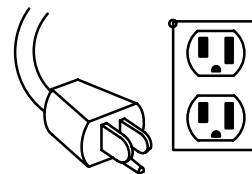

GROUNDING PLUG

06572

This product is intended for commercial use.

SAFETY PRECAUTIONS

The following safety labels are mounted on the machine in the locations indicated. If these or any label becomes damaged or illegible, install a new label in its place.

FOR SAFETY LABEL – LOCATED ON THE MACHINE HANDLE FRAME.



FLAMMABLE SPILLS LABEL – LOCATED ON THE SOLUTION TANK COVER.

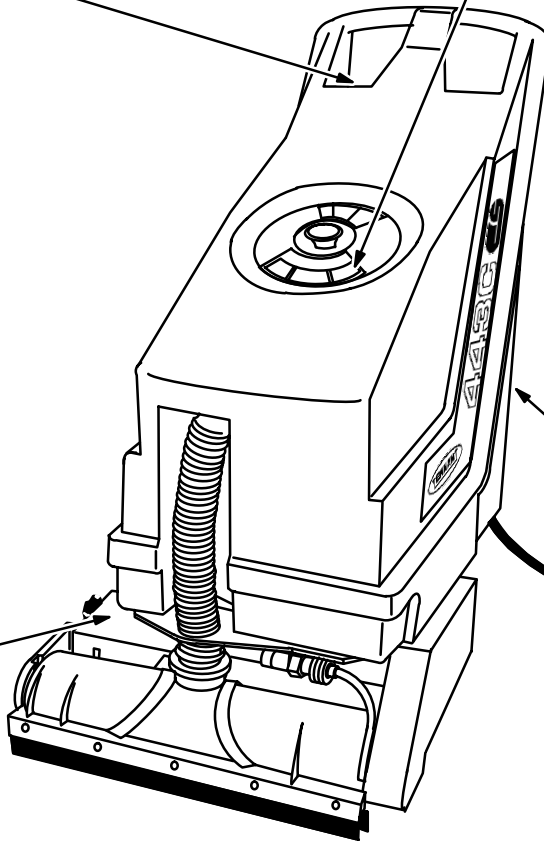
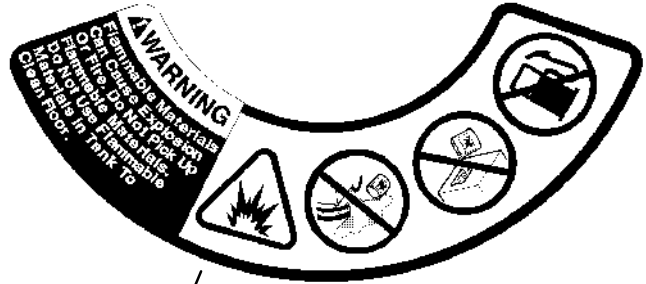

07143



MOVING PARTS LABEL – LOCATED ON THE SCRUB HEAD.



HAZARDOUS VOLTAGE LABEL – LOCATED ON THE REAR PANEL OF THE MACHINE.

SPECIFICATIONS**POWER TYPE**

Electric AC, 110 VAC, 60 HZ

POWER TRAIN

Electric motor, belt driven brush
Electric motor, vacuum fan
Electric motor, solution pump

PROPELLING SYSTEM

Manually propelled with brush assist in forward

SUSPENSION SYSTEM

Casters – (2) rear, 6 in (150 mm) dia
(1) front, 2.5 in (65 mm) dia

SYSTEM REFILL FLUID CAPACITIES

Combined Solution/Recovery tank – 8 gal (30 L)

GENERAL MACHINE DIMENSIONS

Length – 30 in (760 mm)
Width – 20 in (510 mm)
Height – 35 in (890 mm)
Squeegee width – 18.5 in (470 mm)
Cleaning path width – 17 in (430 mm)
Brush width – 17 in (430 mm)
Brush diameter – 3.5 in (90 mm)
Power cord – 40 ft (1015 mm)

MACHINE WEIGHT

Empty solution tank – 107 lb (48 kg)
Full solution tank – 163 lb (73.9 kg)

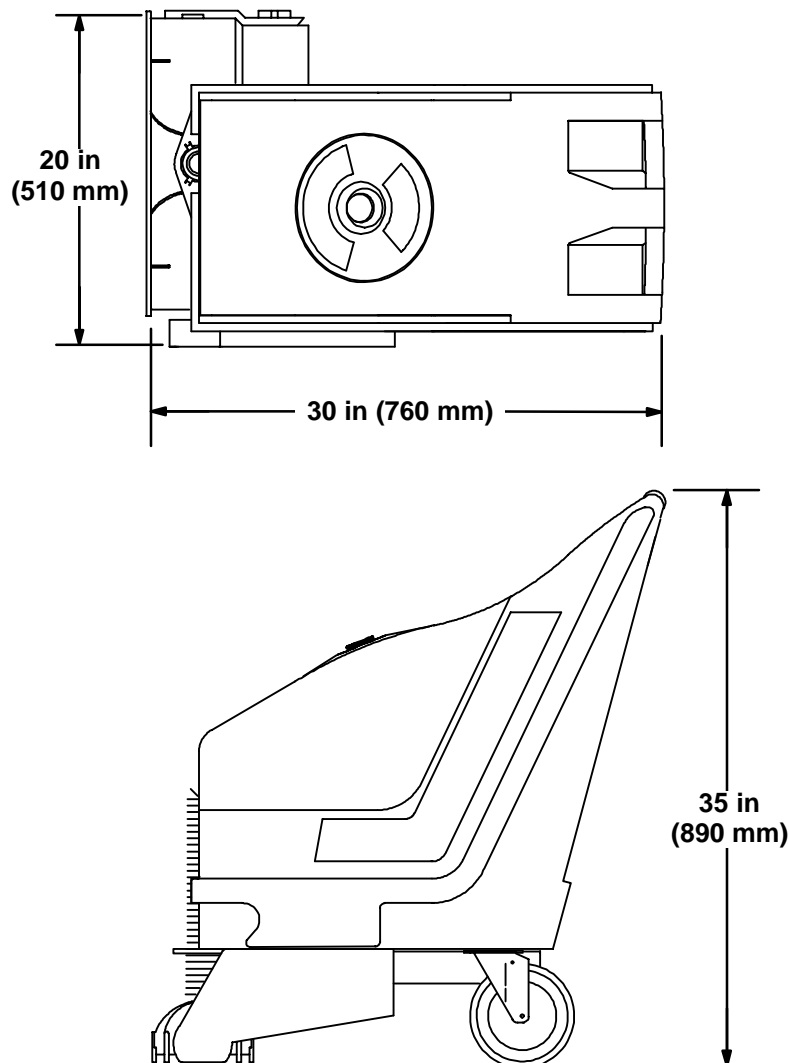
DIMENSIONS

07130

OPERATION

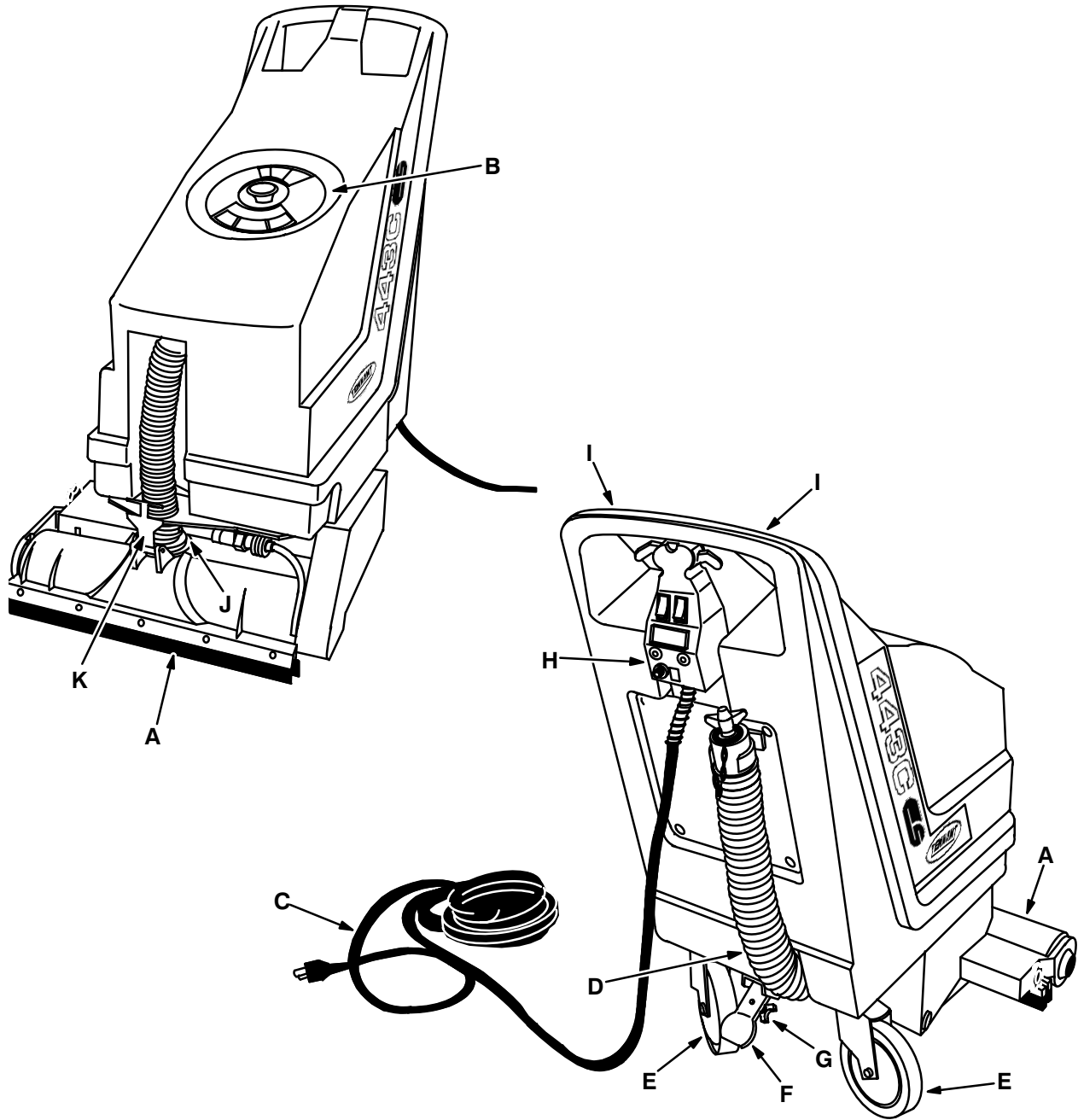

MACHINE COMPONENTS

- | | |
|---------------------------------|---|
| A. Scrub Head | G. Brush Down Pressure Knob |
| B. Solution Tank Cover | H. Control Panel |
| C. Power Cord | I. Machine Handle |
| D. Drain Hose | J. Squeegee Height Adjustment Ring |
| E. Rear Caster | K. Double Scrub Latch |
| F. Scrub Head Lift Lever | |

07143
07144

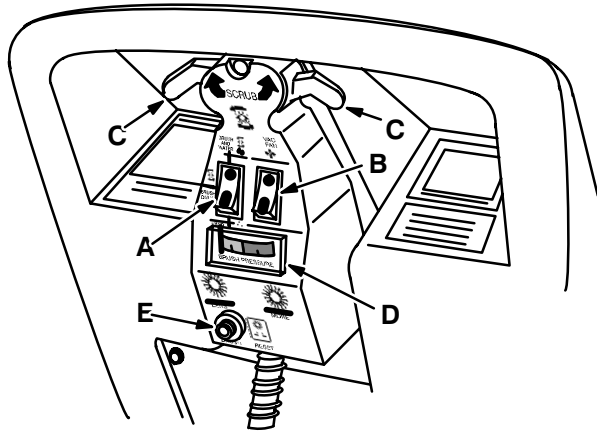

CONTROL PANEL

06206

- A. Mode Switch
- B. Vacuum Fan Switch
- C. Brush/Solution Lever(s)
- D. Brush Pressure Gauge
- E. Brush Circuit Breaker

MODE SWITCH

The mode switch controls various scrubbing functions.

For normal scrub operation, place the mode switch in the BRUSH AND WATER (TOP) position. In this position, both brush and solution pump will operate when either brush/solution lever is activated. Both functions will stop when the lever(s) are released.

For double scrub operation, place the mode switch in the BRUSH ONLY (CENTER) position. When the lever(s) are activated, only the brush will operate; solution will not flow.

For attachment option use, place the mode switch in the WAND (BOTTOM) position. Only the solution pump will operate in this position.

NOTE: Make sure solution dispensing tube is disconnected from the female quick disconnect, or the option is attached to female quick disconnect, otherwise solution will immediately begin to flow onto the floor until the tank is emptied.

VACUUM FAN SWITCH

The vacuum fan switch controls the vacuum fan. Press the bottom (I) of the switch to turn on the vacuum fan. Press the top (O) of the switch to turn off the vacuum fan.

BRUSH/SOLUTION LEVER(S)

The machine has two levers under the machine handles at the top of the control panel. The brush/solution lever(s) turn on the scrub brush and the solution pump. One or both of the levers can be used to start the scrub brush and solution pump when the MODE switch is in the BRUSH AND WATER position. Only the brush will run when the lever(s) are operated if the MODE switch is in the BRUSH ONLY position. In the WAND position, neither the brush nor solution pump are activated by the lever(s).

BRUSH PRESSURE GAUGE

The brush pressure gauge indicates the pressure of the scrub brush on the floor. The brush pressure needle should be at the top of the green zone for the best scrubbing results.

BRUSH CIRCUIT BREAKER

The brush circuit breaker protects the brush motor from overload. If the brush pressure is too high, the brush circuit breaker will trip and the scrub brush will stop. To reset the brush circuit breaker, press the circuit breaker reset button on the circuit breaker. It may be necessary to allow the circuit breaker to cool down before resetting, or it may trip again. Reduce the brush pressure before resuming scrubbing and check the brush for obstructions.

SCRUB HEAD LIFT LEVER

The scrub head lift lever raises the scrub head off the floor. Raise the scrub head with the scrub head lift lever when transporting the machine from place to place, and when the machine is not being used. To raise the scrub head, step on the scrub head lift lever. To lower the scrub head, pull the lever up with the toe of your shoe.

BRUSH DOWN PRESSURE KNOB

The brush down pressure knob adjusts the pressure of the scrub brush against the floor. The brush down pressure knob is located on the underside of the scrub head lift lever. To increase the scrub brush pressure, turn the pressure knob to the left. To decrease the scrub brush pressure, turn the knob to the right.

DOUBLE SCRUB LATCH

The double scrub latch locks the squeegees up. The lever is located on the front of the scrub. Pull up on the lever and hook it onto the frame above the scrub head.

OPERATION

SQUEEGEE HEIGHT ADJUSTMENT RING

The squeegee height adjustment ring adjusts the height of the front and back sets of squeegees located on the scrub head. The adjustment ring is located at the top of the scrub head. Turning the adjustment ring adjusts the height and deflection of the squeegees for proper water pickup. Turn the adjustment ring to the left to increase deflection, and to the right to decrease deflection.

PRE-OPERATION CHECKLIST

Check this list of items over before operating the machine:

Check power cord for any wear or damage.
Do not operate machine with a damaged cord.

TRANSPORTING MACHINE

To move the machine from one place to another, raise the scrub head with the scrub head lift lever. This makes maneuvering the machine easier. When the machine is sitting and not being used, raise the scrub head. This prevents the brush from getting a flat spot. To raise the scrub head, step on the scrub head lift lever until it locks into position. To lower the scrub head, pull up on the scrub head lift lever with the toe of your shoe.

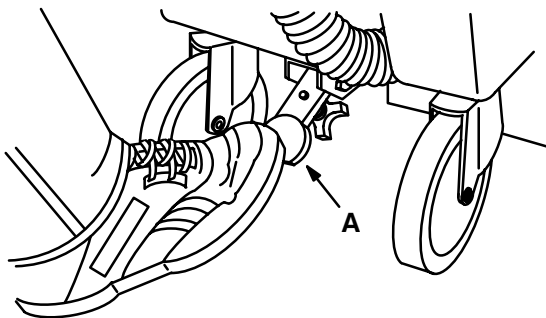

RAISING THE SCRUB HEAD

06210

A. Scrub Head Lift Lever

FILLING THE SOLUTION TANK

1. Unplug the machine and move the machine next to a water source.

WARNING: Hazardous Voltage. Shock Or Electrocutation Can Result. Unplug Power Cord Before Working On Machine.

2. Remove the solution tank cover, letting it hang on the side of the machine.
3. Using a clean bucket or hose, partially fill the tank with hot water through the fill opening.

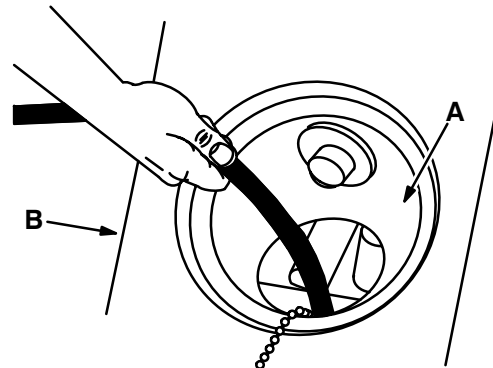

FILLING THE SOLUTION TANK

06215

A. Fill Opening
B. Solution Tank

ATTENTION: Do not use water hotter than 140° F (60° C) in the solution tank or tank damage may occur.

4. Pour the specified amount of detergent into the solution tank. Use TENNANT detergents for best results. Do not use more detergent than is recommended for the job. Powdered detergents are not recommended.

WARNING: Flammable Materials Can Cause An Explosion Or Fire. Do Not Use Flammable Materials In Solution Tank.

5. Fill the solution tank with water up to the bottom link of the chain hanging inside the tank. DO NOT OVERFILL or damage to the vacuum motor may occur.

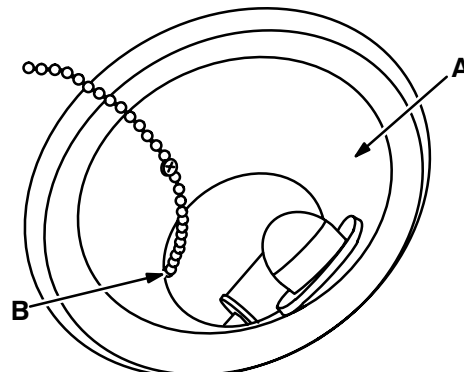

FILL LEVEL OF SOLUTION TANK

06217

A. Fill Opening
B. Bottom Of Fill Chain

NOTE: If the area to be cleaned already has puddles of standing water (such as swimming pool decks), **DO NOT COMPLETELY FILL** the solution tank. Picking up excess water will cause the solution tank to overflow and solution may enter and damage the vacuum motor.

- Place the solution tank cover on the solution tank and make sure the cover gasket seals the tank.

PREPARING FLOOR FOR SCRUBBING

- Sweep or dust mop the entire area to be scrubbed. Loose objects or debris will plug squeegee openings and cause streaking and poor water pickup.
- Remove gum or other such materials stuck to the floor with a putty knife or scraper.
- Determine which cleaning mode is best for the floor condition, *normal scrub* or *double scrub*.

NORMAL SCRUBBING OPERATION

- Plug the machine into a wall outlet.
- Set the MODE switch to the BRUSH AND WATER (TOP) position.
- Turn on the vacuum fan switch.
- Lower the scrub head by pulling up on the scrub head lift lever with the toe of your shoe.
- Pull up on both or one of the switch levers and proceed to scrub. The machine can be pushed and pulled like a vacuum cleaner.
- Watch the water pick-up of the machine. if the machine is leaving water on the floor, adjust the squeegees as follows:

Push the machine forward. Look at the front set of squeegees. The inside squeegee should be straight up and down and touch the floor. The outside squeegee will bend over and touch the inside squeegee.

The same applies for the rear set of squeegees when the machine is pulled backward. The inside squeegee should be straight up and down and touch the floor. The outside squeegee will bend over and touch the inside squeegee.

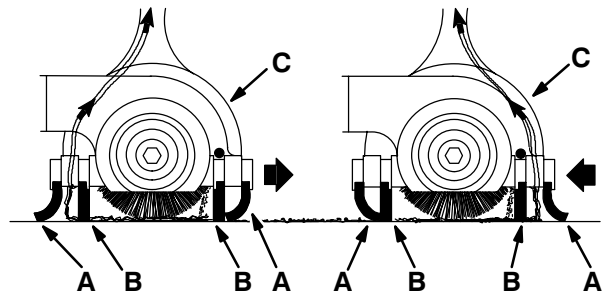

06219

SQUEEGEE ADJUSTMENT

- A. Outside Squeegee Blade**
- B. Inside Squeegee Blade**
- C. Scrub Head**

Both squeegees are adjusted at the same time. To adjust the squeegees, use the squeegee height adjustment ring located on the top of the scrub head. Turn the adjustment ring until the squeegees are adjusted as shown. Pull the machine back and push the machine forward checking the adjustment of the squeegees.

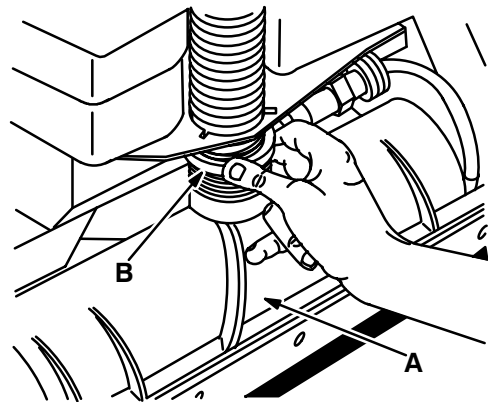

06214

SQUEEGEE HEIGHT ADJUSTMENT RING

- A. Scrub Head**
- B. Squeegee Height Adjustment Ring**

Squeegee adjustment is more precise if the floor is wet with cleaning solution. **DO NOT APPLY TOO MUCH PRESSURE** or the squeegees will smear the floor and wear prematurely.

OPERATION

- Pull up on one or both of the brush/solution levers to check the brush pressure.

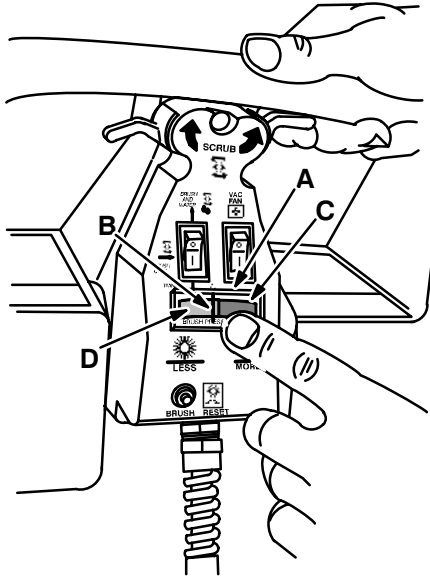

BRUSH PRESSURE GAUGE

06220

- A. Brush Pressure Gauge
- B. Brush Pressure Gauge Needle
- C. Red Zone
- D. Green Zone

The brush pressure gauge needle should be at the top of the green zone. If necessary, adjust the brush pressure with the brush down pressure knob until the brush pressure needle reads at the top of the green zone. The adjustment works better if the floor is wet with cleaning solution.

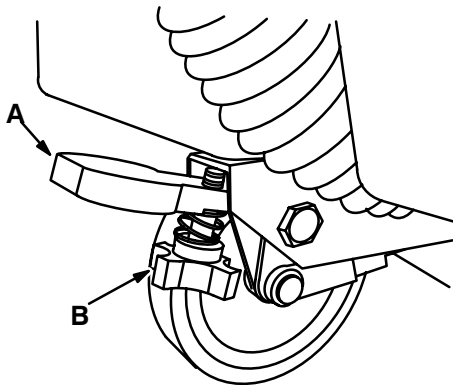

BRUSH DOWN PRESSURE KNOB

06212

- A. Scrub Head Lift Lever
- B. Brush Down Pressure Knob

- Pull up on both or one of the switch levers and proceed to clean. The machine can be pushed and pulled like a vacuum cleaner. The recommended scrubbing path is pushing the machine forward, overlapping paths, much like mowing a lawn.

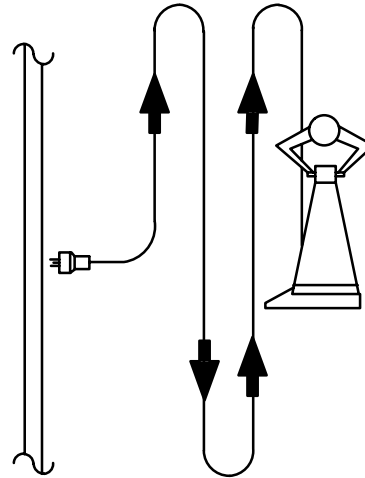

SCRUBBING WITH MACHINE

07179

- When cleaning next to walls or under kickboards, use the operator's right side of the machine for closer scrubbing.
- Watch for foam build-up in the tank through the clear tank cover. If the foam starts rising into the fill area of the solution tank, shut off the machine. Add defoamer to the solution tank, or drain some of the solution from the tank and add clean water.

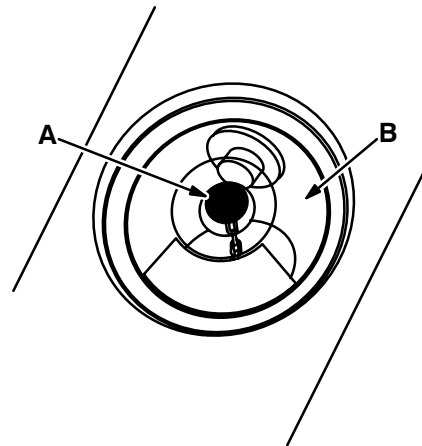

FOAM IN FILL AREA

06222

- A. Solution Tank Cover
- B. Fill Area

- When finished scrubbing, turn off the vacuum fan switch and raise the scrub head by stepping on the scrub head lift lever.

DOUBLE SCRUBBING

Double scrubbing means running the machine over an area several times to get extra scrubbing action. In the double scrub operation, the brush will operate by activating the brush/solution lever(s), but no additional cleaning solution will be applied.

1. Set the MODE switch in the BRUSH ONLY (CENTER) setting.
2. Turn OFF the vac fan switch.
3. Lift up on the double scrub latch and hook it into the machine frame above the scrub head to keep the squeegee blades off the floor.

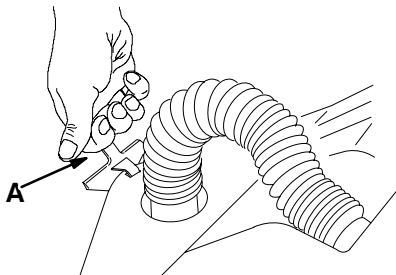

LIFTING UP SCRUB HEAD

08117

A. Double Scrub Latch

4. With the scrub head on the floor, pull up on the brush/solution lever(s) and go slowly over the area you wish to double scrub as many times as necessary. In the double scrub mode, no further cleaning solution will be dispensed.
5. When you have completed double scrubbing, turn on the vacuum fan, and go over the area to vacuum up the solution.
6. When finished scrubbing, turn off the vacuum fan switch and raise the scrub head by stepping on the scrub head lift lever.

DRAINING AND CLEANING THE SOLUTION TANK

1. Unplug the power cord from the wall outlet and place the machine next to a floor drain..

! WARNING: Hazardous Voltage. Shock Or Electrocutation Can Result. Unplug Power Cord Before Working On Machine.

2. Pull the drain hose from the retaining clip on the back of the machine.
3. Loosen the drain plug by turning the drain plug knob to the left.
4. Remove the drain plug while holding the hose up. Quickly lower the hose to the floor drain, as the solution rushes out of the drain hose. Flow rate can be reduced by squeezing the hose.

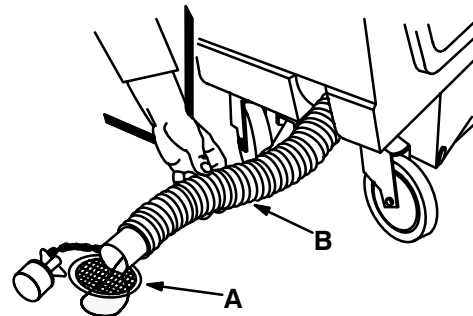

DRAINING THE SOLUTION TANK

06224

- A. Floor Drain**
- B. Drain Hose**

5. With the hose open, flush out the inside of the tank with clean water. Make sure the screen filter at the bottom of the tank is rinsed completely. The filter may be removed for better cleaning by unscrewing it from the fitting. **MAKE SURE THE FILTER IS INSTALLED PRIOR TO USING THE MACHINE AGAIN.** Do not overtighten filter in fitting.

NOTE: Do not use water hotter than 140° F (60° C) in the solution tank or tank damage may occur.

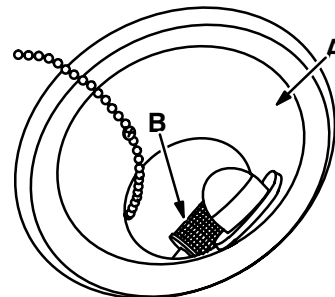

SCREEN FILTER

06217

- A. Solution Tank**
- B. Screen Filter**

OPERATION

6. Pull the vacuum inlet filter out of the side of the fill area and rinse the filter with clean warm water. Push the inlet filter back into the fill area making sure the screen is facing down into the tank.

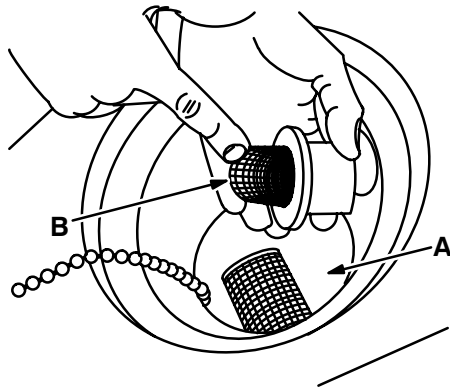

VACUUM INLET FILTER

06226

- A. Fill Area
- B. Vacuum Inlet Filter

7. When the solution tank is completely drained and flushed, place the drain plug back into the end of the drain hose and turn the end of the drain plug to the right to tighten the plug. Place the drain hose back into the retaining clip on the back of the machine.

POST-OPERATION CHECKLIST

Check this list of items over after operating the machine:

- Check power cord for wear or damage. Repair or replace if required. Wipe cord clean and wrap around the machine handles.
- Raise the scrub head by stepping on the scrub head lift lever.
- Flush squeegee housing with hot water, especially if the machine is used in greasy areas.
- Wipe grease/debris build-up from squeegee and squeegee nozzles.
- Check for and remove any string or material wrapped around the scrub brush.
- Check the solution dispensing tube for any plugged holes.
- Check the squeegees for wear or any damage. Replace any worn or damaged squeegees.
- Push the machine to an area to be kept until it is needed again. Be sure the scrub head is raised.
- Freeze protect machine if it will be stored or transported in areas where solution in the system may freeze and damage the components. See *FREEZE PROTECTION* under *STORAGE INFORMATION*.

OPTIONS

POWER WAND

The power wand uses the vacuum system and solution system of the machine. The wand allows scrubbing of floors which are out of reach of the machine.

1. Attach the male end of solution hose to the female quick-disconnect on the machine. Push the male connector in until it stops. Pull on the hose to make sure it is connected.

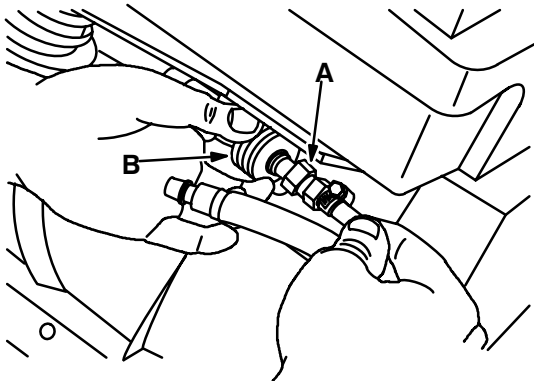

06634

CONNECTING SOLUTION FEED HOSE

- A. Male Quick-Disconnect
- B. Female Quick-Disconnect

2. Pull the vacuum hose off the solution tank, and firmly insert the hose cuff from the power wand hose into the tank.

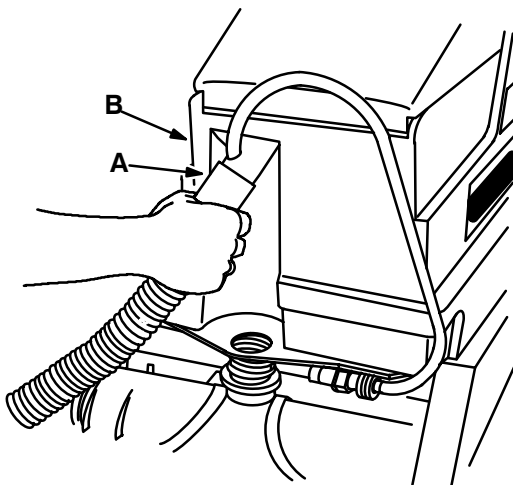

06816

CONNECTING ATTACHMENT HOSE

- A. Wand Attachment Hose
- B. Solution Tank

3. Attach the other ends of the solution and vacuum hoses to the power wand tool in the same way.

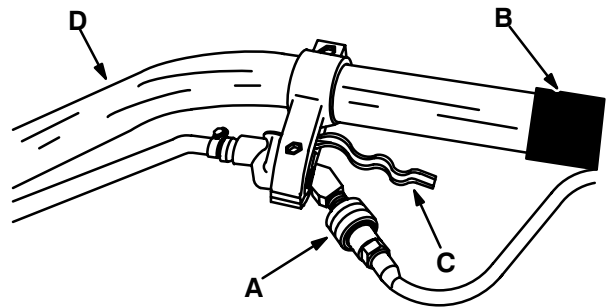

06598

CONNECTING ATTACHMENT

- A. Solution Hose Quick-Disconnect
- B. Vacuum Hose
- C. Valve Handle
- D. Selected Attachment

4. Set the MODE switch to the WAND position. Turn the VAC switch to ON.
5. To scrub with the power wand, turn the cleaning tool so the brush is facing down.

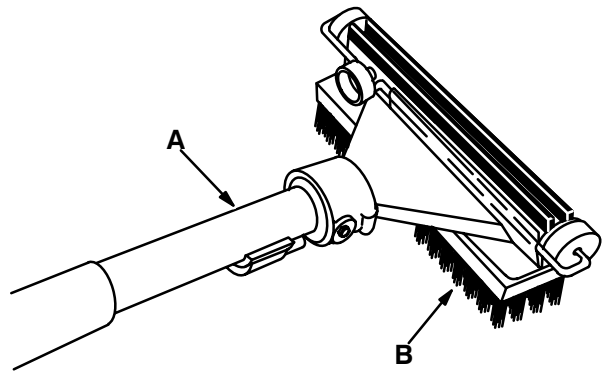

06601

HARD FLOOR WAND

- A. Cleaning Tool
- B. Brush

OPERATION

6. To vacuum up the solution with the power wand, turn the cleaning tool so the squeegee side is facing down. Push and/or pull the tool across the floor to pickup the solution.

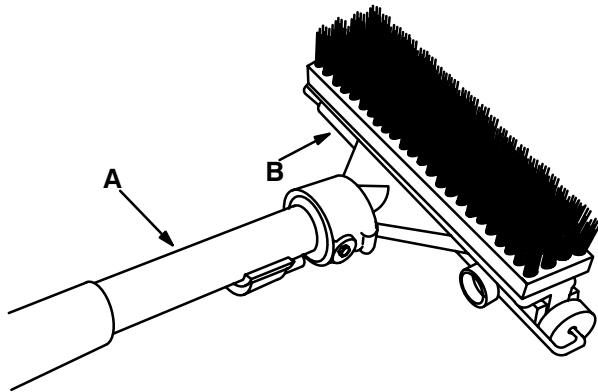

HARD FLOOR WAND

06602

- A. Cleaning Tool
- B. Squeegee

7. If the hard floor wand is difficult to push or does not pickup the solution properly, adjust the roller wheels on the tool by turning the black adjustment knob.

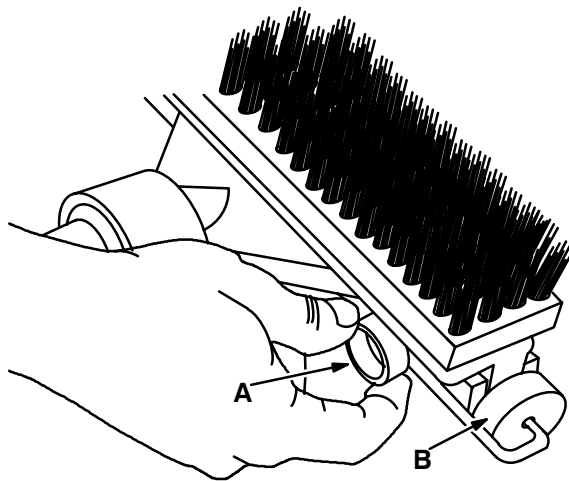

ADJUSTING ROLLER WHEELS

06604

- A. Adjustment Knob
- B. Roller Wheels

8. The wheels are properly adjusted when the squeegee blades deflect slightly while the tool is pushed back and forth.
9. When finished, turn the VAC switch to OFF and set the MODE switch to BRUSH AND WATER (TOP) position.
10. Disconnect the vacuum and solution hoses from the power wand.
11. Disconnect the solution hose from the machine quick-disconnect.
12. Remove the power wand vacuum hose from the solution tank and install the vacuum hose you removed earlier.

MAINTENANCE

MAINTENANCE REQUIREMENTS

The *DAILY*, *WEEKLY*, and *MONTHLY* maintenance requirements listed here may be performed without tools by the machine operators. Instructions for these maintenance requirements are provided in this section of the manual.

The *EVERY SIX MONTHS* maintenance requirements should only be performed by trained technicians.

DAILY

Perform all duties listed under **PRE-OPERATION** and **POST-OPERATION** check lists.

If machine is to be transported or stored under freezing conditions, machine (and any options) must be freeze protected. See *FREEZE PROTECTION* under *STORAGE INFORMATION*.

WEEKLY

Flip the scrub brush end-for-end to prevent a "set" and increase life.

Remove and clean/flush solution dispensing tube.

Remove and clean/flush solution screen filter in the solution tank.

MONTHLY

Remove scrub head from machine, and thoroughly clean.

Check the scrub brush for wear; replace brush if remaining bristles measure less than 0.62 in (20 mm) in length.

EVERY THREE MONTHS

Lubricate brush housing pivot pins/bearings with light oil.

Check and tighten all fasteners/hardware.

EVERY SIX MONTHS

Six month and yearly maintenance is recommended to be performed by technicians from your authorized TENNANT Service Center. Six month maintenance includes weekly and monthly maintenance, plus:

- Vacuum motor brush inspection.
- Brush motor motor brush inspection.
- Solution pump motor brush inspection.
- Brush bearing/seal inspection/ replacement.
- Check brush drive belt alignment/wear. Replace belt if required.

SCRUB HEAD

The scrub head encloses the scrub brush, a solution dispensing tube, a set of squeegee blades mounted on the front and rear. The scrub head and squeegee blades should be flushed daily to remove soil buildup, especially grease, and obstructions.

DAILY FLUSHING OF SCRUB HEAD

1. Unplug the power cord from the wall outlet.

 **WARNING: Hazardous Voltage. Shock Or Electrocutation Can Result. Unplug Power Cord Before Working On Machine.**

2. Raise the scrub head by stepping on the scrub head lift lever with your foot.
3. Position the machine over a floor drain next to a hot water supply with a hose.

MAINTENANCE

4. Disconnect the vacuum pick-up hose from the solution tank inlet.

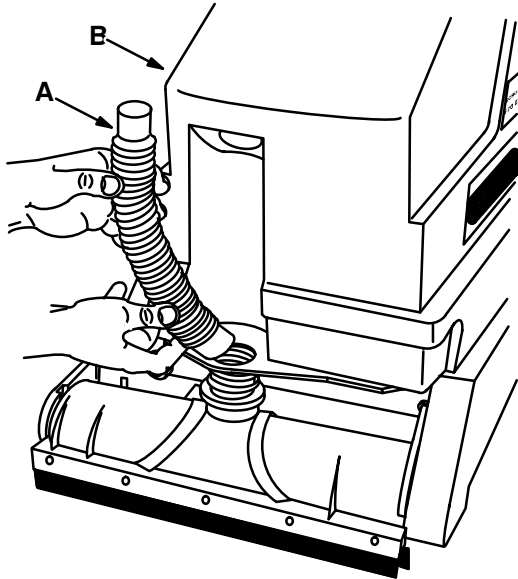

DISCONNECT VACUUM PICK-UP HOSE

06241

- A. Vacuum Pick-up Hose
- B. Solution Tank

5. Using hot water under normal water pressure, insert water hose into the top of the scrub head and allow the water to flush out the housing and blade area.

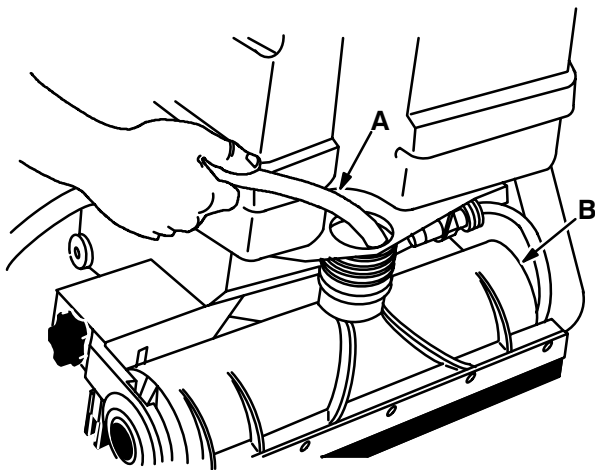

FLUSHING SQUEEGEE HOUSING

06631

- A. Hose
- B. Scrub Head

6. With a wet cloth, wipe off all four (4) squeegee blades to prevent grease buildup. At the same time, inspect each blade for wear or damage. Replace if required.

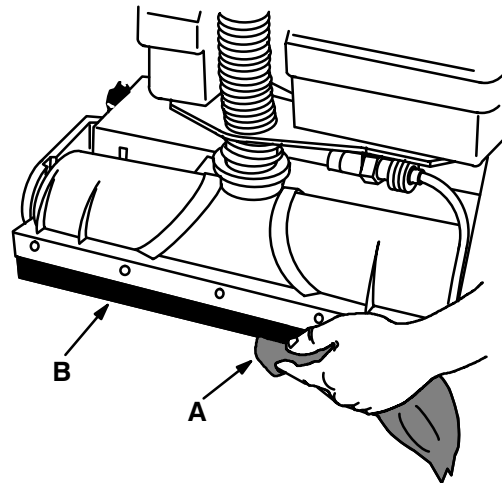

06247

CLEANING SQUEEGEE BLADES

- A. Cloth
- B. Squeegee Blade

7. Re-install vacuum pickup hose on machine.

MONTHLY CLEANING OF SCRUB HEAD

The scrub head should be thoroughly cleaned monthly. Lubricate the pivot pins and bearings at the same time.

1. Unplug the power cord from the wall outlet.

⚠ WARNING: Hazardous Voltage. Shock Or Electrocution Can Result. Unplug Power Cord Before Working On Machine.

2. Remove the scrub head assembly from the machine.

3. Flush the scrub head under clean water. Run water in between the squeegee blades to flush out the vacuum inlets.

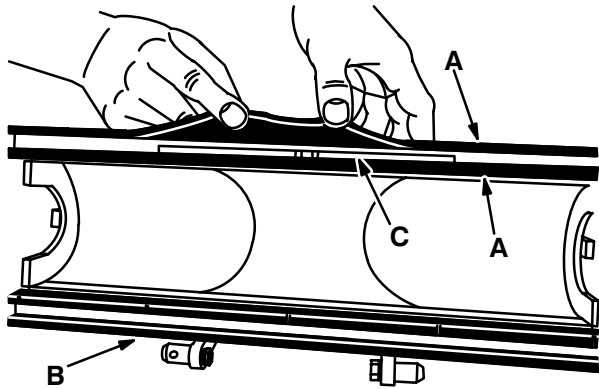

SCRUB HEAD VACUUM INLETS

06248

- A. Squeegee Blades
- B. Scrub Head
- C. Vacuum Inlets

4. Flush the dispensing tube with clean hot water.
5. Place the scrub head back in place on the machine. Pull down on the spring located above the squeegee height adjustment ring and slip the top of the scrub head into the machine. The spring will center the scrub head in the vacuum inlet bracket.
6. Push the side links back onto both sides of the scrub head. Every 3 months, lubricate pins and bearings with light oil.

SCRUB BRUSH

The scrub brush should be checked daily to remove any string or other material wrapped around it. The scrub brush should be flipped end-for-end every week to prevent the bristles from taking a “set” and to increase brush life. The brush should be changed when the remaining bristles measure 0.62 in (20 mm) or less in length.

REPLACING OR ROTATING SCRUB BRUSH

1. Unplug the machine and raise the scrub head by stepping on the scrub head lift lever with your foot.

⚠ WARNING: Hazardous Voltage. Shock Or Electrocutation Can Result. Unplug Power Cord Before Working On Machine.

2. Loosen the brush plate knob by turning to the left. Remove the brush plate knob from the side of the scrub head.

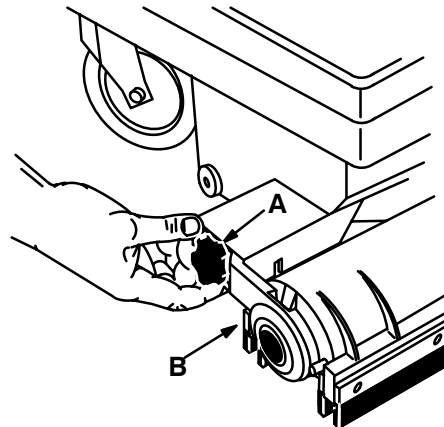

REMOVING BRUSH PLATE KNOB

06234

- A. Brush Plate Knob
- B. Scrub Head

3. Pull the brush plate off the side of the scrub head.

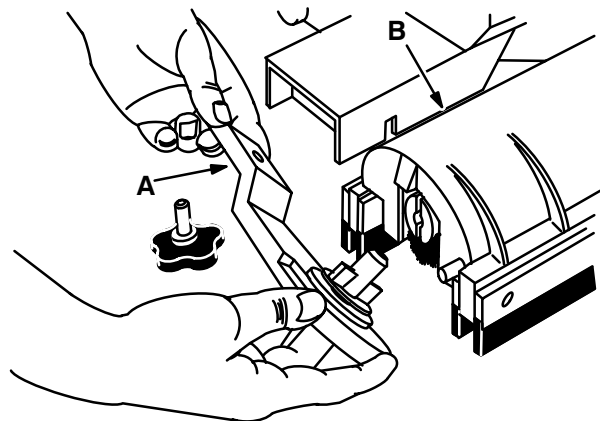

REMOVING BRUSH PLATE

06235

- A. Brush Plate
- B. Scrub Head

MAINTENANCE

4. Pull the brush out of the scrub head.

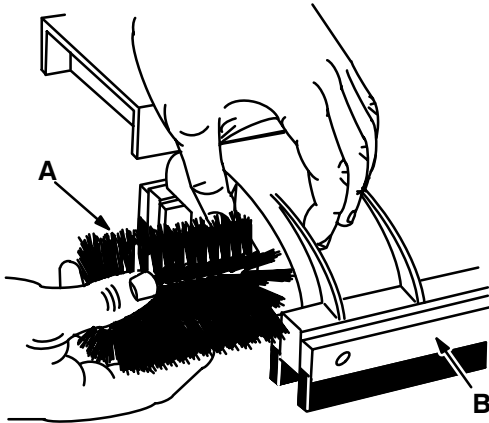

REMOVING BRUSH

06236

- A. Brush
- B. Scrub Head

5. Push the new or flipped brush into the scrub head.
6. Line up the the two slots in brush end with the two tabs on the brush plug on the drive end of the scrub head. Make sure the brush pushes all the way on the brush plug. If the brush does not engage properly on the brush plug, the brush plate will not mount to the machine.
7. Line up the brush plate plug with the end of the brush by putting the tabs on the plug in the brush slots. Place the brush plate knob in the brush plate and mount the brush plate to the side of the scrub head. Turn the brush plate knob to the right to tighten it.

SOLUTION DISPENSING TUBE

The solution dispensing tube is located at the front and on the inside of the scrub head. The small holes drilled in the tube evenly dispense the cleaning solution over the brush. The dispensing tube can be removed from the scrub head for cleaning if required. Clean the tube if the solution does not dispense evenly over the brush.

CLEANING THE DISPENSING TUBE

1. Unplug the machine. Disconnect the solution feed hose from the quick disconnect by pulling back on the knurled sleeve of the female disconnect until the male fitting releases.

! WARNING: Hazardous Voltage. Shock Or Electrocutation Can Result. Unplug Power Cord Before Working On Machine.

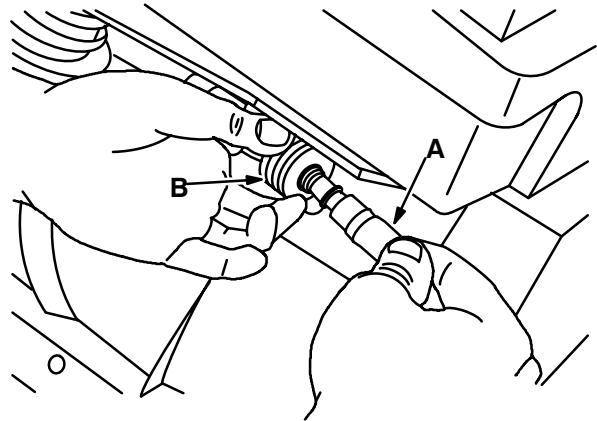

DISCONNECT SOLUTION HOSE

06238

- A. Solution Hose
- B. Female Quick-disconnect

2. A small cap is located on the other end of the dispensing tube. To remove the dispensing tube from the scrub head pull the tube straight out of the scrub head. The small cap will pop off the end of the tube. DO NOT lose the cap. Pull the tube from the housing, taking care not to bend it.

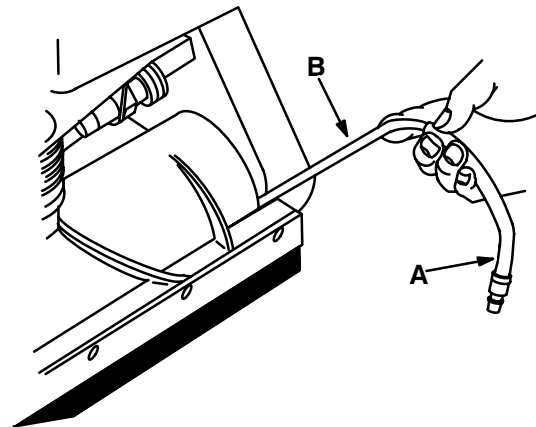

REMOVING DISPENSING TUBE

06239

- A. Solution Hose
- B. Dispensing Tube

3. Clean the small dispensing holes with a piece of wire or a pin, and rinse the tube out with clean hot water.

- Place the tube back in the scrub head.
- Push the cap back on the other end of the tube. Make sure the cap fits tightly on the end of the dispensing tube.

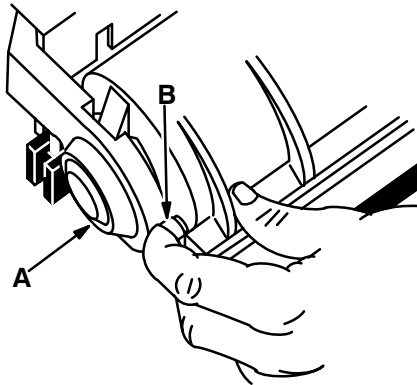

DISPENSING TUBE CAP

06240

- A. Scrub Head**
- B. Dispensing Tube Cap**

- Connect the solution hose male fitting to the female fitting by pulling back on the knurled sleeve on the female and inserting the male fitting. Release the sleeve and make sure the hose is properly connected by pulling lightly on it.

SOLUTION SCREEN FILTER

The solution filter filters the cleaning solution before reuse. The filter is normally flushed clean after every use during the tank flushing procedure. For more thorough cleaning on a periodic basis do as follows:

- Unplug the power cord from the wall outlet.

! WARNING: Hazardous Voltage. Shock Or Electrocutation Can Result. Unplug Power Cord Before Working On Machine.

- Remove cover from solution tank and hang from chain.
- Reach into tank and unscrew the screen filter from fitting by turning to the left.

- Using a hose with warm water under normal pressure, flush the filter from the inside out.

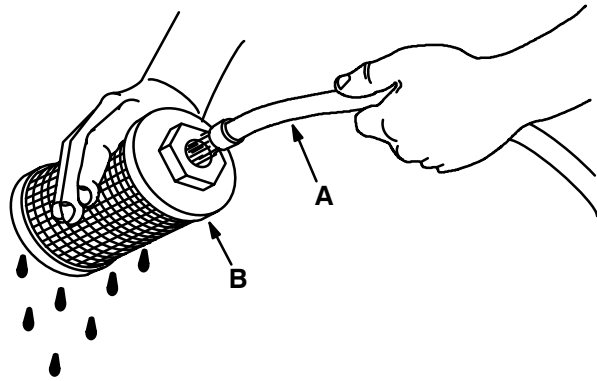

06633

FLUSHING SOLUTION SCREEN FILTER

- A. Solution Screen Filter**
- B. Hose**

- If filter screen material is excessively plugged, soak overnight in a solution of 1 part white vinegar to 10 parts water. Flush with water after soaking.
- Place filter back on to threaded fitting and turn to the right. Do not overtighten.

NOTE: Take care not to damage the filter. Do not operate the machine with the filter removed or if the filter has a hole or tear in it. Do not remove the filter unless the tank is completely drained first. ANY DEBRIS ENTERING THE PUMP INTAKE LINE WILL DAMAGE THE PUMP.

REMOVING THE SCRUB HEAD ASSEMBLY

The following procedure is recommended if all squeegee blades are being replaced, and/or if the scrub head is being cleaned under the *MONTHLY CLEANING OF SCRUB HEAD*. It is recommended that the pivot pins and bearings be lubricated at the same time.

- Unplug the power cord from the wall outlet.

! WARNING: Hazardous Voltage. Shock Or Electrocutation Can Result. Unplug Power Cord Before Working On Machine.

- Remove the scrub brush.
- Disconnect the solution hose quick disconnect.

MAINTENANCE

4. Disconnect the vacuum pick-up hose from the top of the scrub head.

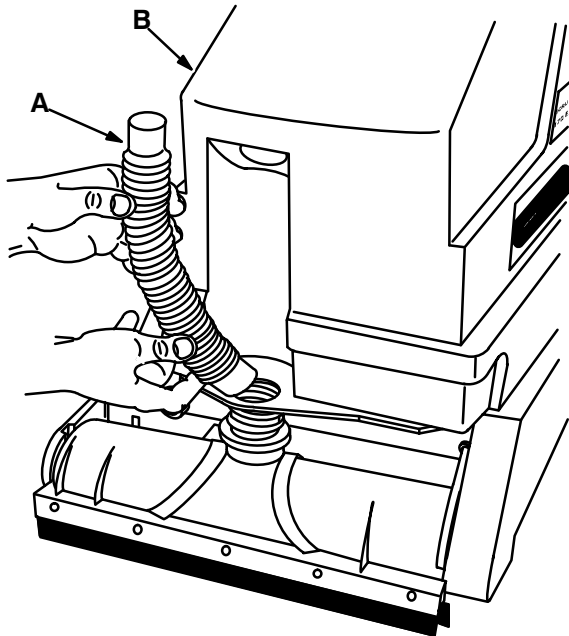

06241

DISCONNECT VACUUM PICK-UP HOSE

- A. Vacuum Pick-up Hose
- B. Solution Tank

5. Pull the side links off both sides of the scrub head.

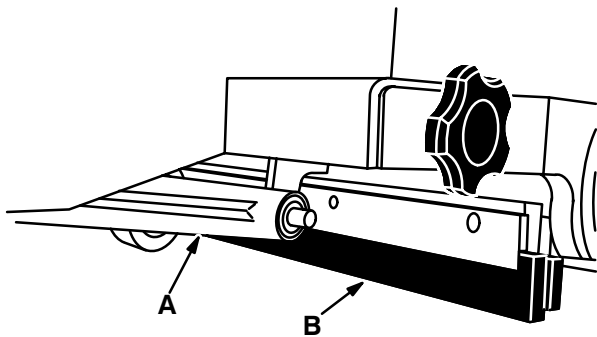

06242

RIGHT SIDE SCRUB HEAD LINK

- A. Scrub Head Link
- B. Scrub Head

6. Pull the spring located above the squeegee height adjustment ring down and remove the scrub head from the machine.

7. Turn the scrub head upside-down.
8. To reinstall the scrub head assembly, place the scrub head back in place on the machine. Pull down on the spring located above the squeegee height adjustment ring and slip the top of the scrub head into the machine. The spring will center the scrub head in the vacuum inlet bracket.
9. Push the side links back onto both sides of the scrub head. Every 3 months, lubricate pins and bearings with light oil.
10. Connect the solution hose quick disconnect.
11. Connect the vacuum pick-up hose to the top of the scrub head.
12. Install the brush in the scrub head.

SQUEEGEE BLADES

The scrub head has 2 sets of 2 squeegee blades on the front and back. These blades squeegee up the solution off the floor in the forward and reverse directions. The front and rear squeegee blades (with the many corrugations) should be checked for damage and wear daily. When the inside wiping edge of the front and rear (corrugated) blades become rounded or have tears in them, they will not pick up solution properly. Replace any worn or damaged squeegee blades. The inside squeegee blades (the ones with the slots) normally only need to be checked monthly.

REPLACING SQUEEGEE BLADES

1. Unplug the power cord from the wall outlet.

WARNING: Hazardous Voltage. Shock Or Electrocution Can Result. Unplug Power Cord Before Working On Machine.

2. Raise the scrub head by stepping on the scrub head lift lever with your foot.

- Grasp the end of the squeegee blade(s) that need replacing and pull it sideways out of the blade retainer. Use a dry cloth to grasp the squeegee blade if needed.

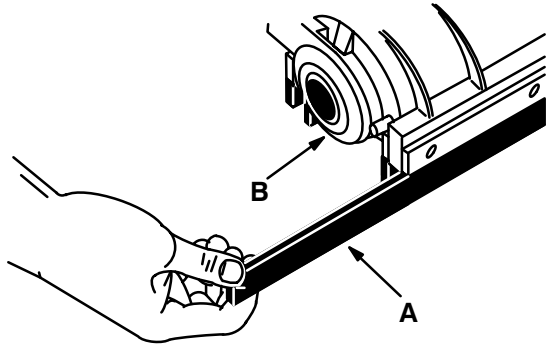

REMOVING SQUEEGEE BLADE

06632

- A. Squeegee Blade
- B. Scrub Head

- Lubricate new squeegee blade in water/detergent from tank. Pull new squeegee blade into the scrub head blade retainer until it is centered in the scrub head. Use a dry cloth if needed to grip squeegee while pulling it into retainer.
- If all the squeegees need to be replaced, remove the scrub head assembly from the machine.
- Pull out any squeegee blades that need replacing.

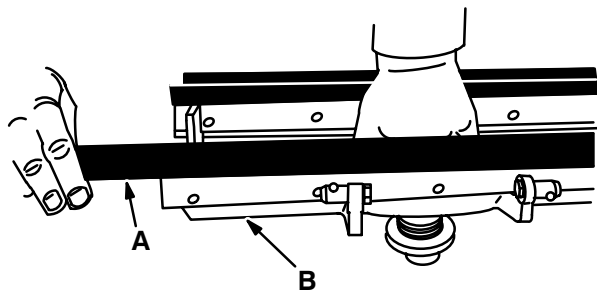

REMOVE SQUEEGEE BLADE

06246

- A. Squeegee Blade
- B. Scrub Head

NOTE: Use a dry cloth to help get a grip on the squeegee blade end to pull the blade out of the scrub head.

- Pull the new squeegee blade into the scrub head from the blades end until the blade is centered in the scrub head.

NOTE: Lubricate the new squeegee blade with some detergent to make pulling the blade into the scrub head much easier. Use a dry cloth to help get a grip on the squeegee blade end to pull the blade out of the scrub head.

- Flush out the scrub head assembly and install it back on the machine.

STORAGE INFORMATION

Freeze protection of the machine is necessary to prevent damage to components of the solution system when the machine is going to be exposed to freezing temperatures.

ATTENTION: Freezing temperatures can severely damage components. Do not store or transport machine in areas where freezing of solution contents could occur, unless machine is freeze protected. Failure of components due to lack of freeze protection voids the warranty on such components.

FREEZE PROTECTION

- Pour 1 gal (3.8 L) of pre-mixed automotive-type windshield washer solution into solution tank.

ATTENTION: Do not use cooling system anti-freeze such as ethylene glycol.

- Move machine over floor drain and plug the power cord into an outlet.
- Set the MODE switch in the WAND position. The pump will start and spray through the feed tube to the floor. Run in this manner until all of the solution is dispensed.

ATTENTION: Machines and attachments that have been freeze protected must be flushed completely prior to normal use. Follow directions for the appropriate cleaning process, but run your selected cleaning solution through the system to purge all anti-freeze before starting the cleaning process.

MAINTENANCE

TROUBLESHOOTING

| PROBLEM | PROBABLE CAUSE | REMEDY |
|--|--|--|
| Machine does not operate | Power cord not plugged in | Plug into proper receptical |
| | Building circuit breaker tripped | Reset breaker |
| | Power cord/plug damaged | Repair or replace |
| | Electrical malfunction | Call Service Center |
| Vacuum motor does not operate when switch activated. | Worn motor brushes | Replace |
| | Electrical malfunction | Call Service Center |
| Pump does not run; solution will not dispense to floor. | MODE switch is in wrong position | Move switch to proper position |
| | Solution tank is empty or low | Fill solution tank |
| | Quick-disconnect not connected | Connect properly |
| | Tank filter is plugged | Remove and clean filter |
| | Solution feed tube is plugged | Remove and clean tube |
| | Electrical or pump malfunction | Call Service Center |
| Brush does not run | MODE switch is in wrong position | Move switch to proper position |
| | Circuit breaker is tripped | Reset breaker (reduce brush pressure) |
| | Drive belt broken | Replace |
| | Electrical malfunction | Call Service Center |
| Brush circuit breaker trips | Excessive brush pressure | Reduce brush pressure |
| | Electrical malfunction | Call Service Center |
| Brush does not clean floor | Excessive soil may require several passes to clean | Double scrub area |
| | Brush worn | Replace brush |
| | Improper chemical for job | Select proper chemical |
| Solution feed will not shut off. | MODE switch in improper position | Move switch to proper position |
| | Pump malfunction | Repair or replace |
| Poor vacuum pickup or streaking | Squeegee intake slots plugged | Clean |
| | Improper squeegee adjustment | Adjust |
| | Poor gasket seal on tank cover | Repair or replace |
| | Worn or damaged squeegee blades | Replace blades |
| Foam builds up in cover area and/or foam exits motor louvers | Excessive or improper chemical used | Drain tank and refill with proper dilution |
| | Solution level too high | Reduce solution level below chain |
| | Air leak in cover gasket | Repair or replace |